

CHATOYER

FLOATING BAFFLE USER GUIDE



Spill Containment
on Land



Spill Containment
on Water



Liquid Containment



Stormwater
Protection



Silt & Sediment
Control



Bags & Covers



Water Diversion



Spill Control

1300 880 623
sales@chatoyer.com.au
chatoyer.com.au

FLOATING BAFFLE USER GUIDE



The purpose of a Floating Baffle is to improve the operating efficiency of a waste water treatment system. These systems may make up part of a sewage treatment plant, industrial waste water treatment plant or other treatment processes related to mining or the oil and gas sectors.

A Floating Baffle system contributes to the efficiency of a waste water treatment process by preventing short circuiting of water flows and improving the utilisation of pond volume. This increases the retention time within the pond to optimise sedimentation settling.

Baffles are available in a variety of sizes and designs which are easily installed in existing lagoons or ponds, without draining, by using the baffle's built in flotation as an aid to installation.

WHAT COMPONENTS ARE USED IN A FLOATING BAFFLE?

A Floating Baffle or Curtain consists of flotation components supporting an engineered fabric with ballast along the skirt bottom. As Floating Baffles are often commissioned with a required project life greater than 10 years, Chatoyer brings together high quality components matched with high quality fabrication to comfortably meet the project expectations.

Flotation Components

The flotation for a Floating Baffle is generally provided by either:

- Closed Cell Foam logs integrated into a sealed pocket formed by the baffle geomembrane
- Rotationally moulded polyethylene bolt on floats which sit externally on the baffle

The method for selecting the form of flotation is usually determined by a number of factors including:

- The length of the Floating Baffle
- The chosen geomembrane material
- The required life of the project

Engineered Fabric

The choice of fabric utilised in the Floating Baffle is related to the anticipated life expectancy of the installed baffle. Chatoyer generally fabricates with a polypropylene geomembrane due to the confidence this material provides with respect to meeting the critical challenges of liquid containment and contaminant control. This polypropylene geomembrane carries a manufacturers warranty of 10 years or longer.

Floating Baffles can also be manufactured from a PVC fabric which is suitable for a shorter project life. This material is an alternative for temporary pond arrangements.

Ballast

A hanging skirt of a baffle is not directly anchored and therefore ballast must be used to maintain the structure integrity. Chatoyer use a continuous ballast to provide constant and measured weight across the length of the skirt bottom. For protection, the ballast will be housed within a sealed pocket formed by the geomembrane. The continuous ballast will be provided in varying gauges to meet the requirements of the baffle design and will either be Galvanised Steel or Grade 316 Stainless Steel.



DEPLOYING THE FLOATING BAFFLE



Floating Baffle systems as manufactured by Chatoyer are delivered with sections pre-assembled and packed on heavy duty pallet skids or within treated wooden crates. The assembly plan for the system should be studied and the section designations noted. Pallet markings should be checked for start and finish sections and the pallets aligned in order as close as possible to the deployment zone.

The skirt is gathered and pre-tied to the baffle's floats, then packed in a flaked design for easy unloading and deployment. Multiple sections of Floating Baffle will be joined together and packed onto the pallet or crate. Where the total length of baffle system requires multiple pallets to ship, individual sections (of multiple panels) will need to be joined at the time of deployment to create the complete system.

Remove the packaging carefully so as to not damage the contents. The baffle should then be flaked out into the water. As the last section comes off the first pallet or wooden crate, release the skirt ties on the end 3-4 metres of the baffle panel. This will allow the skirt depth to unfurl sufficiently to enable connection along the length of the skirt. The ties along the 3-4 metre length of the next baffle section to be joined should also be released and the sections connected. Specific instructions for the connection of each baffle section will be included in the packaging.

As the baffle is being deployed, it is floated across the lagoon to its anchoring destination on the opposite embankment. This can be accomplished with the aid of a small boat and a line, or a line can be run from the baffle's far end connection across the lagoon to the opposite shore to pull the baffle across.

Temporary anchors are useful during deployment to hold the baffle in position while end connections are being made and connected.

Floating Baffle skirt ties should not be cut until the baffle has been floated into position within the pond and tensioned between the anchoring posts.

BANK MOORINGS

For more permanent bank moorings, there are a series of techniques that can be used to secure the Floating Baffle to the bank. The type of mooring used should take into account water level movements and of course the anticipated force load. Most permanent moorings involve some civil works to be completed and should be implemented as part of a wider project.

A Dead Man Anchor or an Anchor Post secured by concrete and dug into the embankment are the most common approaches. These bank moorings can be further reinforced using either a Screw Anchor.

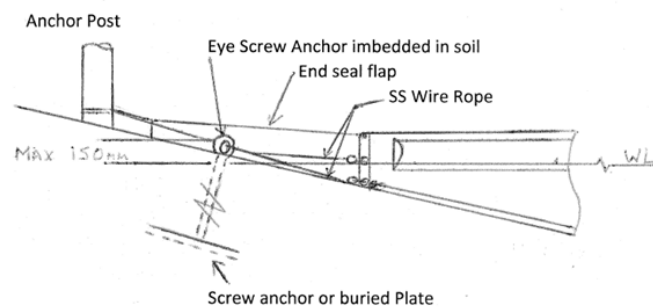

INTERMEDIATE ANCHORING

Intermediate side anchors are installed depending upon the baffle length and operating or environmental conditions. These conditions include the shape of the pond, the force of the wind and the quantity of water flowing through the lagoon and against the Floating Baffle system. Side anchors relieve the strain on the baffle caused by combinations of these forces between shore and anchor posts. If required, Intermediate Anchors must be installed on both side of the Floating Baffle system to keep the baffle centred.

An Intermediate Anchor system consists of marine grade rope attached from the connector to a buoy. For baffle systems implementing dual tension members above and beneath the float section, a wire bridle is placed between the connector and the tether line. An anchor line approximately 4 times the water's depth is attached to the buoy from the chain and the anchor. Once the anchor has been set, it may be necessary to adjust the anchoring line so the baffle system remains in position with equal tension on the tether lines on either side of the baffle. Or a Flat Plate.

Where the Floating Baffle system end point will be greater than 150mm height from the Anchor Post, an eye screw should be used to control the horizontal positioning of the baffle.



SELECTING AN ANCHOR

The type of anchor best suited to the Floating Baffle system depends upon the lagoon construction and also the operating conditions of the lagoon or pond.

Self digging style anchors such as Danforth Anchors can be used but they have a limited holding power in soft bottoms. Large concrete blocks are a good choice for soft bottom lagoons as they will settle into the sediment.

When using concrete blocks, the buoyancy of the concrete needs to be taken into account. This means a factor of approximately 10 must be taken into account to generate the required holding strength.



The installation of a Floating Baffle or other floating architecture within in a lined pond will require a different form of anchoring so as to not damage the liner. Concrete anchoring blocks will naturally move slightly under the water which will result in the edges or roughness of the concrete damaging the liner. A common approach to anchoring in lined ponds is to deploy rubber tyres filled with concrete. The rubber casing will decrease the potential damage from concrete rubbing against the geomembrane.

The holding strength required from the anchors will depend upon the operating conditions. In the case where large anchoring forces are required and it is impractical to deposit large and heavy anchors, multiple smaller anchors can be used to generate a similar anchoring weight. Ideally, anchors are placed (embedded where possible) in new ponds prior to filling.

Storms and high winds can move anchors around which results in a mispositioned baffle system. This may have the effect of short circuiting the water flows and hence the system should be regularly checked with routine maintenance carried out to ensure its effectiveness.

INSPECTION & MAINTENANCE

If the Floating Baffle system is to be deployed for an extended period (greater than 12 months), it is recommended that an Inspection & Maintenance schedule be implemented to maximise the effectiveness and longevity of the baffle system.

Typical Inspection & Maintenance activities include:

- Review and confirmation of the positioning of each baffle
- Reviewing the integrity of the fabric and connection points such as connectors and zips
- Replacing worn or broken anchor lines
- Inspect and report on any sludge build up which may be placing undue pressure on the system
- Review of floats and skirts with respect to fouling (mostly from bird life)
- Clean down Floating Baffle system if required
- Hardware is often placed under pressure, especially at anchoring points and the wear and tear on these parts should also be considered

CHATOYER

chatoyer.com.au

1300 880 623

sales@chatoyer.com.au

Copyright © 2021 Chatoyer Environmental Pty Ltd.