



Ultra-Pellet Pan[®] Composite Model

Part # 7200 - 7235

Installation Instructions

Before beginning the installation process, a detailed review of your Ultra-Pellet Pan order is recommended to make sure that all items have been received and are not damaged. Please refer any questions or problems immediately to your UltraTech Distributor or to UltraTech International, Inc. at (800) 353-1611. Do not attempt to install your Ultra-Pellet Pan system if any parts are missing or damaged.

All installation personnel should read this document in its entirety BEFORE the installation process begins.

NOTE: Proper personal protection equipment must be worn while installing Ultra-Pellet Pans, Composite Model. All safeguards must be taken to insure that the area of track where installation is to take place will have no rail traffic or other activity that may present hazards to installation personnel. All applicable OSHA, DOT and other governing regulations must be followed. UltraTech International, Inc. is not responsible in any manner for equipment, property or personnel used in the Ultra-Pellet Pan installation process.

THE FOLLOWING INSTALLATION INSTRUCTIONS HAVE BEEN PREPARED WITH THE ASSUMPTION THAT A COMPLETE ULTRA-PELLET PAN SYSTEM (I.E., CENTER PELLETT PANS WITH GRATES, SIDE PELLETT PANS WITH GRATES) IS BEING INSTALLED. IF, AS AN EXAMPLE, YOUR INSTALLATION REQUIRES CENTER PELLETT PANS ONLY, DISREGARD ALL REFERENCES TO THE INSTALLTION OF SIDE PELLETT PANS.

Required Tools:

1. Metal Rake
2. House Broom
3. Shovels
4. Tape Measure
5. Adjustable C-Clamps
6. Marking Crayon
7. Channel Lock pliers (12 inch), adjustable wrench, or socket set

Site Preparation:

1. Before installing Ultra-Pellet Pans, Composite Model, minor preparation of the installation area is, in most cases, required. Outline the area in which the Ultra-Pellet Pans are to be installed. Ultra-Pellet Pans are approximately 20 feet in length. Multiply 20 feet x the number of center pans in your system and this will give you the approximate length of the system. With an appropriate tape measure and marking crayon, mark the beginning and end of the system on the foot of the rails. Within this area any ballast, weeds, or other debris that is higher than the top of the ties needs to be removed. Before the Ultra-Pellet Pans are installed the ballast in this area needs to be flush with or lower than the tops of the ties. If your system includes side pellet pans then the ballast on the field side of the rails will need to be flush with or lower than the tops of the ties and away from the rail three to five feet from the web of the rail.
2. **JOINT BARS:** Joint bars hold two pieces of rail together. They are typically placed on the gauge side and field side of the rail web and are bolted together with six bolts (three bolts facing in toward the middle of the track and three facing out.) If possible, remove joint bars and the bolts and weld the rails together. If this is not possible inspect joint bars and bolts and make sure they are fully tightened using an appropriate wrench. Once they are securely tightened, place a metal cutting blade on the circular saw, and wearing proper hearing and eye protection, cut off the excess threads of these bolts. If your system only contains center pellet pans then the bolts facing out do not need to be cut off.
3. **RAIL ANCHORS:** Rail anchors prevent the rails from moving on the railroad ties as the locomotive pulls or stops the train. You will notice them in the area between the rails. Usually they are opposite one another and against the ties. In some situations these anchors may need to be removed and replaced with a low profile anchor or removed altogether. Contact UltraTech and/or the Railroad for additional guidance. Ultra-Pellet Pans, Composite Model are designed to accommodate most standard rail anchors, including pandrols. NOTE: Extremely large rail anchors may be a problem and should be checked with a pan placed over the rail anchor prior to moving forward with the install.
4. **RAILROAD SPIKES:** Check all Railroad Spikes to see that they are all driven down tight to the foot of the rail.
5. Remove dirt and other debris that may have collected on the inside and outside web surfaces of both rails.
6. Finally, sweep off the tops of the ties leaving a clean surface on which to install the Ultra-Pellet Pan System.

DISCLAIMER: UltraTech International, Inc. assumes no liability for damages incurred to Ultra-Pellet Pans or the Ultra-Pellet Pan system due to installation on railroad ties that are in poor condition and thus enabling the rail anchors to damage the pans. UltraTech International, Inc. also assumes no liability for damages incurred to the Ultra-Pellet Pans or the Ultra-Pellet Pan system or loss of containment by the Ultra-Pellet Pan system caused by failure to remove and replace track joint bars or splice bars.

General Installation Guidelines:

IMPORTANT: Your pellet pan order has been customized to meet your needs. The Pellet Pan walls that will be located at the very beginning and the very end of each System have NOT been trimmed.

Installation of Center Pellet Pans:

1. The BEGINNING center pellet pan should be installed with the untrimmed, contoured portion of the pan at the STARTING END of the pellet pan system. The opposite side of this pan will have a vertical trim:

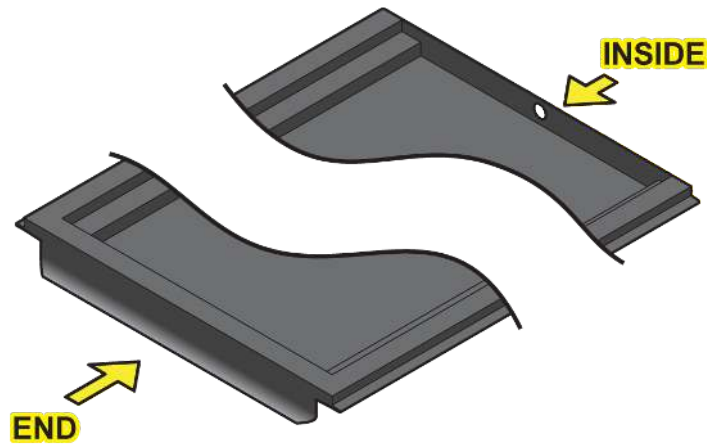

2. It is important to install the center pellet pans so that they are centered between the two rails. This will facilitate the installation of the center pellet pan gaskets at the end of this process. In order to keep them centered UltraTech recommends cutting four blocks of quarterboard (5/4) wood 6 inches long. These blocks are to be used as spacers to keep the center pellet pans centered between the two rails while assembling.

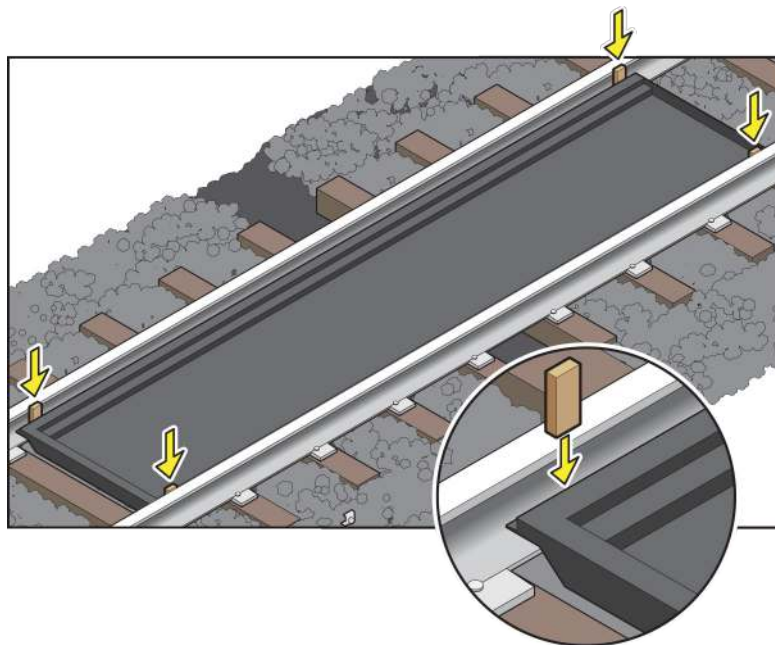

3. The second center pan should begin with the horizontal trim side. Set this pan down so the horizontal trim covers the vertical trim of pan #1, but allowing enough room for grates (if applicable) to fit.
4. Continue this process until all center pans have been installed.



Installation of Side Pellet Pans

NOTE: IT IS IMPORTANT TO NOTE THAT THERE ARE SIGNIFICANT DESIGN DIFFERENCES ON THE OUTSIDE SURFACE OF THE LONG SIDES OF THE PELLET PANS. ONE (1) SIDE CONTOURS ALL THE WAY TO THE GROUND. THIS IS THE SIDE THAT MUST BE POSITIONED ON THE FIELD SIDE, AWAY

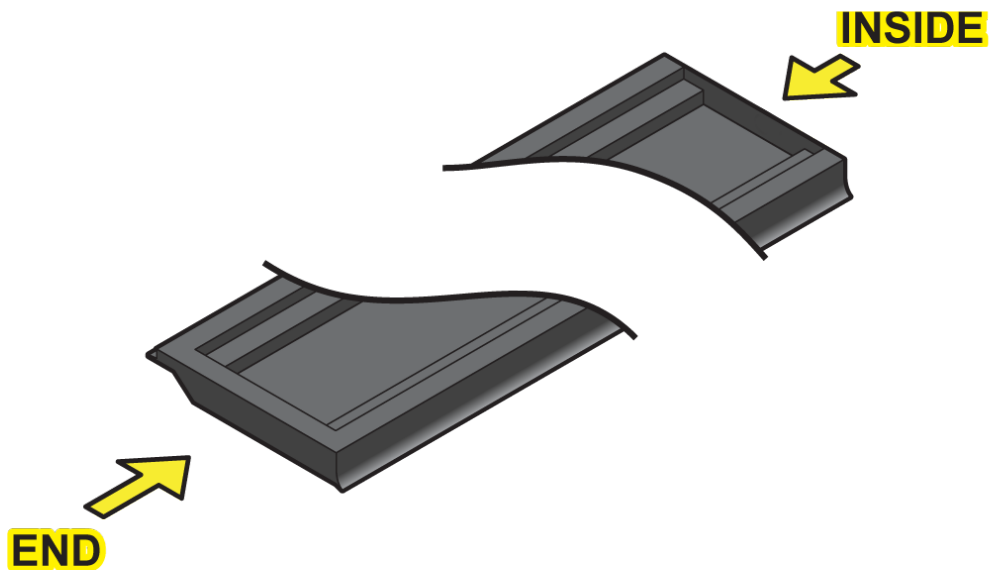

FROM THE RAIL WEB.

1. Space out the two side pan rail clips evenly throughout the length of the side pan, making sure that the location of each side pan rail clip is between railroad ties.
2. With the “L” portion of the side pan rail clip aligned towards the field side of the rail, slide the other

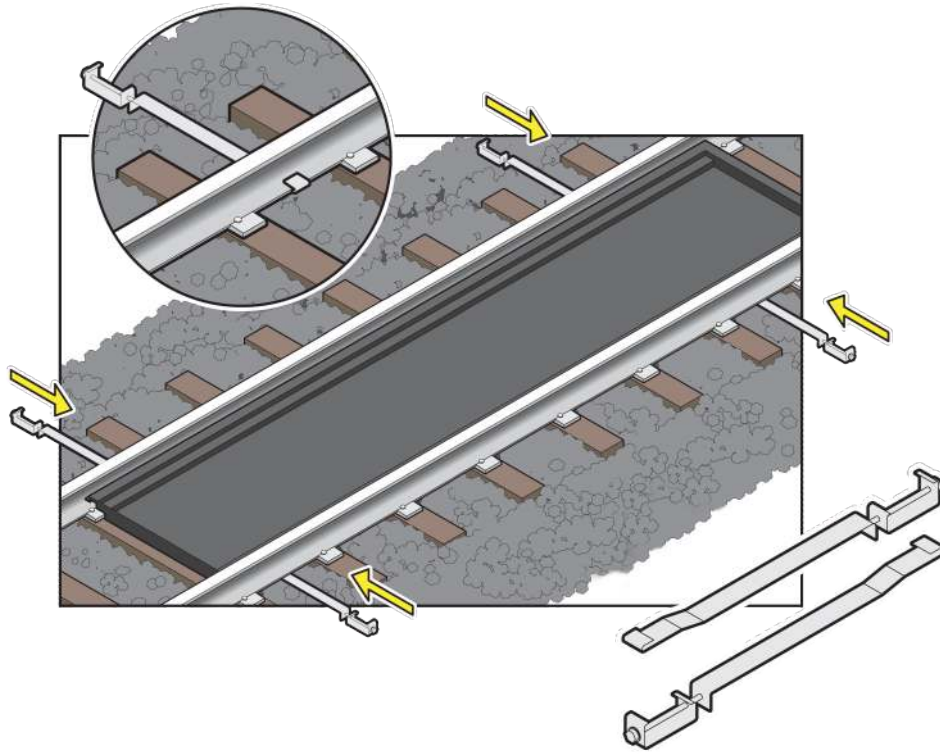

- end of the side pan rail clip under the rail and pull back until it is secure against the rail.
3. Stand the contoured, field-side of the side pan into the notches on the two “L” portions of the side pan rail clips. These “L”s will support the outside structure of the side pan and help prevent sagging and cracking over time on the field side of the side pan in addition to holding the pan in place.
 4. Slowly lower the side pan towards the rail until it is sitting flat on the railroad ties. Insert the two 5/4

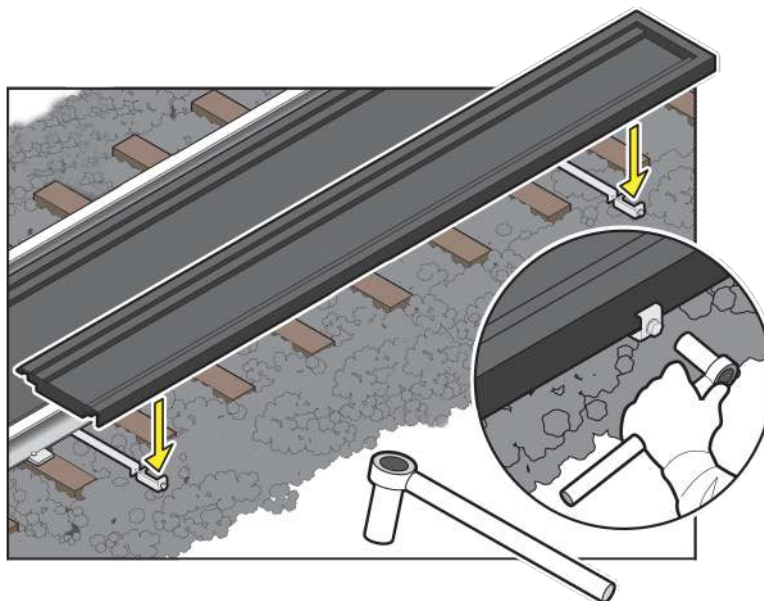

shims between the rail and the edge of the side pan:

5. With the shims in place, tighten the bolts of the side pan rail clips until the clips are holding the side pan against the shims. **DO NOT OVERTIGHTEN** the bolts, as it may cause the resin of the side pan to crack.
6. The second side pan should begin with the horizontal trim side. Set this pan down so the horizontal trim covers the vertical trim of pan #1, but allowing enough room for grates (if applicable) to fit.
8. Continue this process until all side pans on one side have been installed.
9. Repeat steps for opposite side.
10. Continue with this process until all of the Ultra-Pellet Pans have been installed.

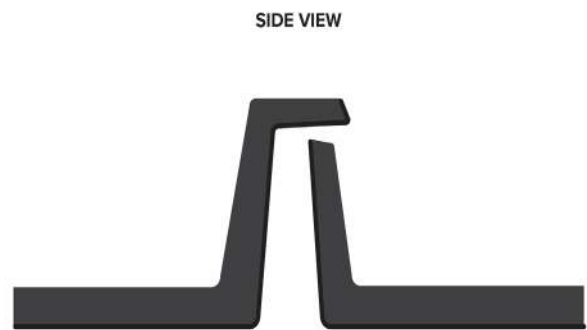
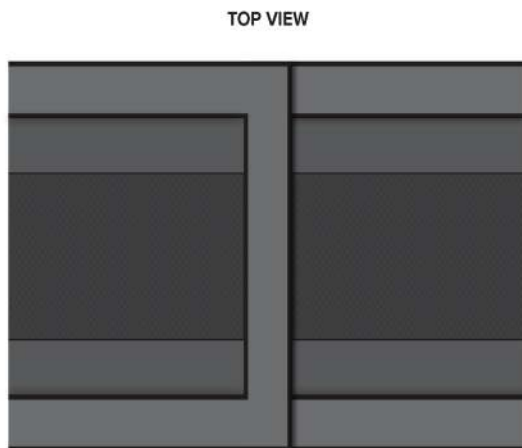

The basic order of installation should be:

1. Center pan (1)
2. Center pan (2) to center pan (1)
3. Side pan (1A)
4. Side pan (2A) to side pan (1A)
5. Side pan (1B)
6. Side pan (2B) to side pan (1B)
7. Center pan (3) to center pan (2)
8. Side pan (3A) to side pan (2A)
9. Side pan (3B) to side pan (3B)
10. And so on, until the system is complete.

Installing gaskets

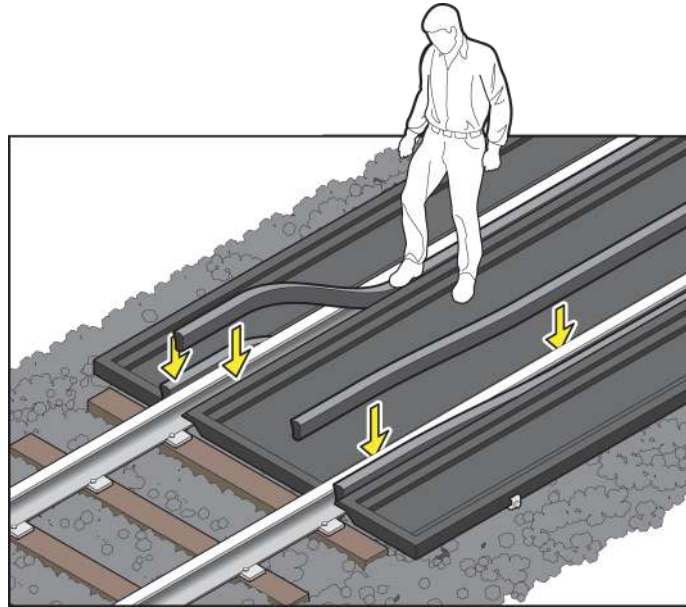

1. Position one gasket on each side of the center pellet pan.
2. If using grates as a walking surface for the Ultra-Pellet Pans, Composite Model, prepare ten grates for each center pan by inserting two grating pedestals into the diamond on the underside of each grate. These pedestals will prevent the grates from sagging over time.
3. Position ten grates in each center pan, using the grating locator positions on the pans.

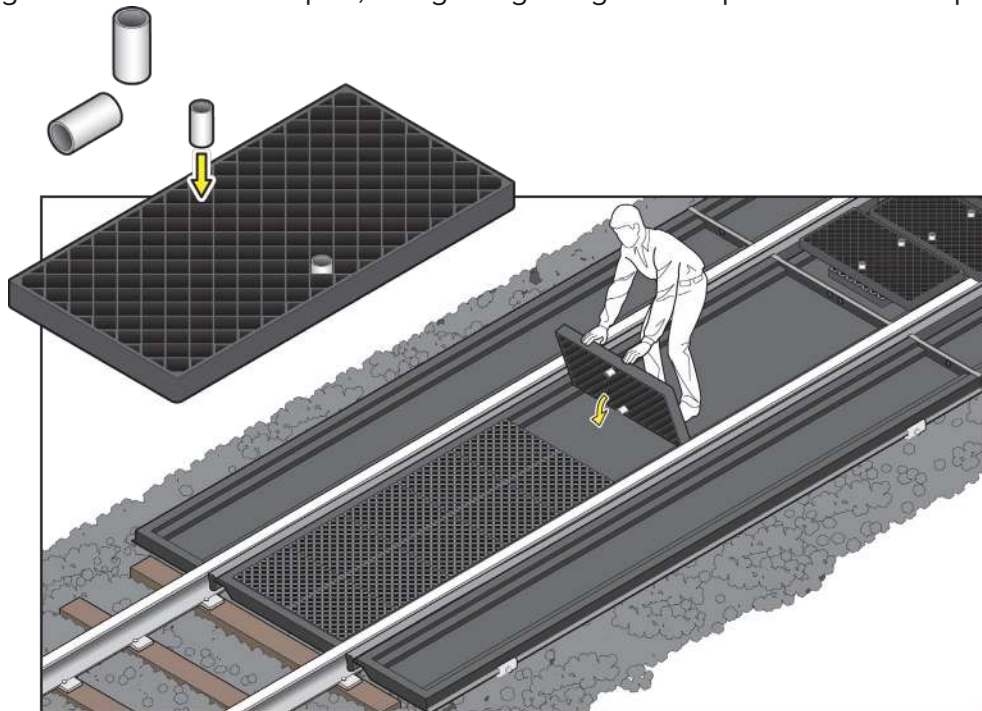

4. If using gaskets to seal the Ultra-Pellet Pans, Composite Model to the rails, position one gasket on rail side of the side pellet pan.
5. If using grates as a walking surface for the Ultra-Pellet Pans, Composite Model, position five grates in each side pans, using the grating locator positions on the pans.

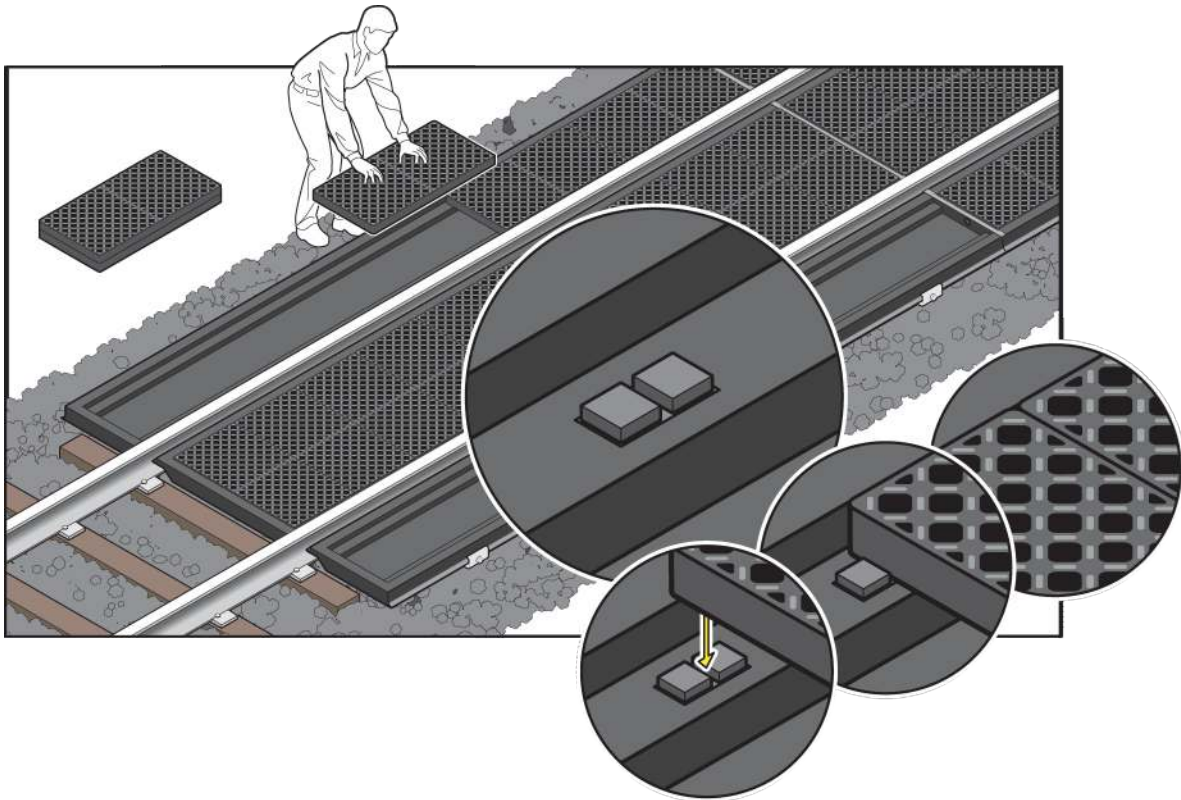

Your Pellet Pan system should now be ready and fully operational. If you have any questions, please call us at 800-353-1611 or 904-292-1611. You can also email us at info@trackpans.com