

MADE IN
AUSTRALIA



Spill Containment
on Water

SOLID FILLED CONTAINMENT BOOM

Solid Filled Oil Containment Booms are an impervious floating barrier designed to deflect or contain spills or floating debris. With our standard crumble resistant, closed cell foam flotation chamber and continuous skirt draft, these booms perform very well in rough weather.

SPECIFICATIONS

Height	(mm)	450	650
Freeboard	(mm)	150	200
Draft	(mm)	300	450
Ballast Chain	(mm)	6	8
Connectors	Universal ASTM Z-connector		
Handles	Every 3 metres		
Weight	(kg/m)	4	4.35

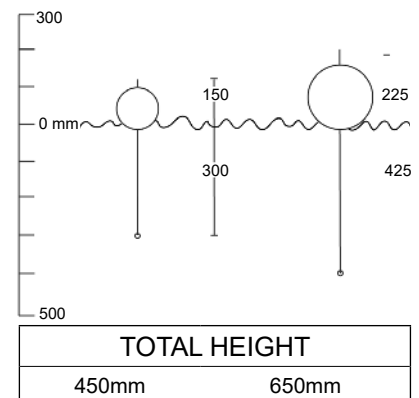

APPLICATIONS

Ponds	Marinas
Rivers	Dams
Harbours	

OPTIONS & ACCESSORIES

Carry bag	Tow bridle
Ground sheet	Anchor Kits

MATERIALS

Fabric	PVC, 610gsm, UV resistant
Ballast	Hot dipped galvanised steel chain enclosed in continuous pocket
Connectors	Marine grade aluminium
Handles	50mm webbing



Spill Containment
on Water



1300 880 623
sales@chatoyer.com.au

CHATOYER